

Fire-Rated Assemblies
Stark Truss Company, Inc.

PR-S223

Revised December 14, 2018

Products: SI-40, SI-60, and SI-80 Prefabricated Wood I-Joists
Stark Truss Company, Inc.
8655 Chestnut Ridge Road, N.W.
Beach City, Ohio 44608
(330) 756-3050
www.starktruss.com

1. Basis of the product report:
 - 2018, 2015, 2012, and 2009 International Building Code (IBC): Sections 104.11 Alternative materials, 703 Fire-Resistance Ratings and Fire Tests, 721 Prescriptive Fire Resistance, 722.6 Wood assemblies, and 2303.1.2 Prefabricated wood I-joists
 - 2018 and 2015 International Residential Code (IRC): Sections R104.11 Alternative materials, R302.13 Fire protection of floors, and R502.1.2 Prefabricated wood I-joists
 - 2012 and 2009 IRC: Sections R104.11 Alternative materials, R502.1.4 Prefabricated wood I-joists, and R501.3 Fire protection of floors (2012 IRC only)
 - ASTM D5055-13e1, D5055-13, D5055-09 and D5055-05 recognized by the 2018 IBC and IRC, 2015 IBC and IRC, 2012 IBC and IRC, and 2009 IBC and IRC, respectively
 - American Wood Council Design for Code Acceptance DCA 3, Fire-Rated Wood-Frame Wall and Floor/Ceiling Assemblies
 - APA System Report SR-405
 - ICC-ES ESR-2919 and ESR-1405
 - ASTM E119 full-scale fire test reports, and engineering analyses
2. Product description:

Stark Truss SI Series I-joists covered in this report, as described in Table 1, are made with lumber flanges and oriented strand board (OSB) webs in accordance with the in-plant manufacturing standard approved by APA, as documented in ICC-ES ESR-2919.
3. Design properties:

Design properties for Stark Truss SI Series I-joists are provided in ICC-ES ESR-2919.
4. Product installation:

Stark Truss SI Series I-joists covered in this report shall be installed in accordance with the recommendations provided by the manufacturer (www.starktruss.com).
5. Fire-rated assemblies:

Stark Truss SI Series I-joists have been shown through testing and engineering analysis to achieve the fire resistance ratings described in this report. Fire-rated assemblies for Stark Truss SI Series I-joists shall be constructed in accordance with the prescriptive requirements provided in this report or recommended by the manufacturer (see link above). In addition, Stark Truss SI Series I-joists shall be permitted for use in the fire rated assemblies described in Section 4.2.2.2 (Assembly 2) of ICC-ES ESR-1405, and Stark Truss SI Series I-joists with a minimum depth of 9-1/2-inch shall be permitted for use in the fire rated assembly described in Sections 4.2.2.3 (Assembly 3) and 4.2.2.1 (Assembly 1) of ICC-ES ESR-1405, when installed in accordance with the requirements specified therein.
6. Fire-protection of floors:

Stark Truss SI Series I-joists, as shown in Table 2, when installed and protected as specified in APA System Report SR-405 (www.apawood.org/resource-library) meet the requirements of 2018 and 2015 IRC Section R302.13, and 2012 IRC Section R501.3 or are alternatives to the 2-by-10 dimension lumber prescribed in Exception 4 to 2018 and 2015 IRC Section R302.13, and 2012 IRC Section R501.3 with demonstrated equivalent fire performance.

7. Limitations:
- a) Stark Truss SI Series I-joists covered in this report shall be designed in accordance with the code using the design properties specified in ICC-ES ESR-2919.
 - b) Stark Truss SI Series I-joists covered in this report are limited to dry service conditions where the average equilibrium moisture content of sawn lumber is less than 16 percent.
 - c) Stark Truss SI Series I-joists covered in this report are produced at the Stark Truss Company, Inc. facility in Beach City, Ohio under a quality assurance program audited by APA.
 - d) This report is subject to re-examination in one year.
8. Identification:
 Stark Truss SI Series I-joists described in this report are identified by a label bearing the manufacturer's name (Stark Truss Company) and/or trademark, the APA assigned plant number (1039), the I-joist depth and series, the APA logo, and a means of identifying the date of manufacture.

Table 1. Description of Stark Truss SI Series I-joists^(a)

Joist Series	Joist Depths (in.)	Flanges			Web	
		Material	Dimension		Material	Thickness (in.)
			Depth (in.)	Width (in.)		
SI-40	9-1/4 – 11-7/8	Proprietary SPF	1-1/2	2-1/2	OSB	3/8
SI-60	9-1/4 - 16	MSR SPF	1-1/2	2-1/2	OSB	3/8
SI-80	11-1/4 - 16	MSR SPF	1-1/2	3-1/2	OSB	3/8

^(a) Referenced dimensions are nominal. Tolerances are as specified in the in-plant quality manual.

Table 2. Applicable SI Series I-joists for SR-405 Assemblies

Assembly in SR-405	Applicable Joist Series
FP-01	SI-40, SI-60, and SI-80
FP-02	SI-40, SI-60, and SI-80
FP-03	SI-40, SI-60, and SI-80
FP-04	SI-40, SI-60, and SI-80
FP-05	SI-40, SI-60, and SI-80
FP-06	SI-40, SI-60, and SI-80
FP-07	SI-40, SI-60, and SI-80
FP-09	SI-40, SI-60, and SI-80



Stark Truss Company Assembly SI1.1

One-Hour Fire Resistance Rated Floor/Ceiling Assembly*

This fire resistance design is listed in accordance with the International Building Code (IBC) and American Wood Council's *Design for Code Acceptance (DCA) 3*

SI-80

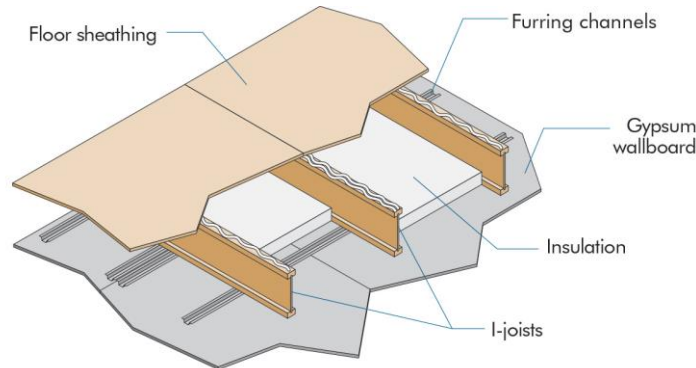

A. BASIC ASSEMBLIES

- 1) Floor Topping (Optional): Varies (reference sound ratings if applicable).
- 2) Floor Sheathing: Min. 23/32-inch (18-mm) T&G Wood Structural Panel. A construction adhesive must be applied to the top of the joists prior to placing sheathing. The sheets shall be installed with their long edge perpendicular to the joists with end joints centered over the top flange of joists. Floor sheathing must be installed per code requirements.
- 3) Insulation: Min. 1-1/2-inch (38-mm) Mineral Wool Insulation Batts (min. 2.5 pcf). Installed adjacent to the bottom flange of the I-joist and supported by the furring channels. Ends of batts shall be centered over furring channels.
- 4) Structural Members: Min. 9-1/4 inches (235 mm) Deep I-Joists. Max. 24 inch (610 mm) on center spacing. Min. flange thickness of 1-1/2 inches (38 mm) and each flange area of at least 5.25 inches² (3,387 mm²). Min. web thickness of 3/8 inch (9.5 mm).
- 5) Furring Channels: Min. 0.026-inch (0.66-mm) Hat Shaped Galvanized Steel Channels attached perpendicular to the bottom flange of the I-joist with 1-5/8-inch (41-mm) Type S drywall screws. Channels are spaced a max. of 16 inches (406 mm) on center, are doubled at each wallboard end joint, and extend to the next joist beyond each joint.
- 6) Ceiling: One layer of 5/8-inch (16-mm) Type C Gypsum Wallboard. Installed with long dimension perpendicular to furring channels and fastened with min. 1-1/8-inch (29-mm) Type S drywall screws spaced at 12 inches (305 mm) on center on intermediate joists and 8 inches (203 mm) on center at end joints, and 3/4 inch (19 mm) from wallboard edges and ends. The end joints of the wallboard must be staggered.
 - a) Finish: The face layer joints must be covered with tape and coated with joint compound. Screw heads must also be covered with joint compound.

B. SOUND RATING^(a)

Components	STC	IIC
Base Assembly with Carpet and Padding, Gypsum Concrete	49	59

^(a) Sound ratings from the American Wood Council publication *Design for Code Acceptance (DCA) 3*. Available from www.awc.org/publications/DCA/DCA3/DCA3.pdf.

C. SIMILAR ASSEMBLIES

- 1) 2009 IBC Table 720.1(3) Item 24-1.1, 2012/2015/2018 IBC Table 721.1(3) Item 24-1.1, and DCA 3 WIJ-1.1

* This assembly may also be used in a fire-rated roof/ceiling assembly, but only when constructed exactly as described.

REPRESENTING THE ENGINEERED WOOD INDUSTRY



Stark Truss Company Assembly SI1.3

One-Hour Fire Resistance Rated Floor/Ceiling Assembly*

This fire resistance design is listed in accordance with the International Building Code (IBC) and American Wood Council's Design for Code Acceptance (DCA) 3

SI-40, SI-60, and SI-80

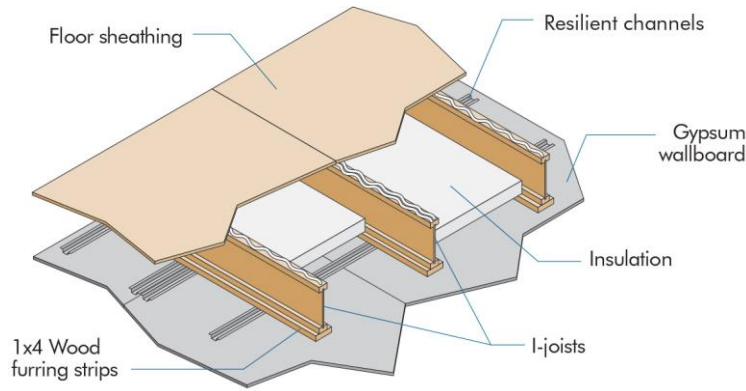

A. BASIC ASSEMBLIES

- 1) Floor Topping (Optional): Varies (reference sound ratings if applicable).
- 2) Floor Sheathing: Min. 23/32-inch (18-mm) T&G Wood Structural Panel. The sheets shall be installed with their long edge perpendicular to the joists with end joints centered over the top flange of joists. Floor sheathing must be installed per code requirements.
- 3) Insulation: Min. 2-inch (51-mm) Mineral Wool Insulation Batts (min. 3.5 pcf). Installed adjacent to the bottom flange of the I-joist and supported by 1x4 wood furring strip spacer. The ends of the batts shall be centered over resilient channels.
- 4) Structural Members: Min. 9-1/4 inches (235 mm) Deep I-Joists. Max. 24 inches (610 mm) on center spacing. Min. flange thickness of 1-5/16 inches (33 mm) and each flange area of at least 2.25 inches² (1,452 mm²). Min. web thickness of 3/8 inch (9.5 mm).
- 5) Wood Furring Strip Spacers: Min. nominal 1 inch (25 mm) x 4 inches (102 mm) attached with 1-1/2-inch (38-mm) long drywall screws at 24 inches (610 mm) on center along the bottom of the bottom flange of each I-joist.
- 6) Resilient Channels: Min. 0.019-inch (0.5-mm) Galvanized Resilient Channels (1/2-inch or 13-mm deep single leg). Attached perpendicular to the wood furring strip and bottom flange of the I-joist with 1-7/8 inch (48-mm) Type S drywall screws. Channels are spaced a max. of 16 inches (406 mm) on center, are doubled at each wallboard end joint, and extend to the next joist beyond each joint.
- 7) Ceiling: One layer of 5/8-inch (16-mm) Type C Gypsum Wallboard. Installed with long dimension perpendicular to resilient channels and fastened with min. 1-1/8-inch (29-mm) Type S drywall screws spaced at 7 inches (178 mm) on center, and 3/4 inch (19 mm) from wallboard edges and ends. The end joints of the wallboard must be staggered.
 - a) Finish: The face layer joints must be covered with tape and coated with joint compound. Screw heads must also be covered with joint compound.

B. SOUND RATING^(a)

Components	STC	IIC
Base Assembly with cushioned vinyl	51	46
Base Assembly with Carpet and Padding	52	66
Base Assembly with cushioned vinyl, Gypsum Concrete	60	48
Base Assembly with Carpet and Padding, Gypsum Concrete	60	60

^(a) Sound ratings from the American Wood Council publication Design for Code Acceptance (DCA) 3. Available from www.awc.org/publications/DCA/DCA3/DCA3.pdf.

C. SIMILAR ASSEMBLIES

- 1) 2009 IBC Table 720.1(3) Item 23-1.1, 2012/2015/2018 IBC Table 721.1(3) Item 23-1.1, and DCA 3 WIJ-1.3

* This assembly may also be used in a fire-rated roof/ceiling assembly, but only when constructed exactly as described.

REPRESENTING THE ENGINEERED WOOD INDUSTRY



Stark Truss Company Assembly SI1.4
One-Hour Fire Resistance Rated Floor/Ceiling Assembly*

This fire resistance design is listed in accordance with *American Wood Council's Design for Code Acceptance (DCA) 3*
SI-40, SI-60, and SI-80

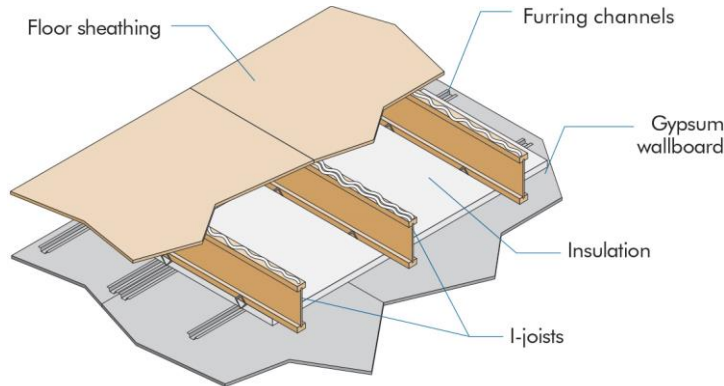

A. BASIC ASSEMBLIES

- 1) Floor Topping (Optional): Varies (reference sound ratings if applicable).
- 2) Floor Sheathing: Min. 23/32-inch (18-mm) T&G Wood Structural Panel. The sheets shall be installed with their long edge perpendicular to the joists with end joints centered over the top flange of joists. Floor sheathing must be installed per code requirements.
- 3) Insulation: Min. 1-inch (25-mm) Mineral Wool Insulation Batts (min. 6 pcf) with width equal to on-center spacing of the I-joists. Installed below the bottom flange of the I-joint and on top of furring channels with sides butted against support clips. The ends of the batts shall be centered over furring channels with batts tightly butted at all joints.
- 4) Structural Members: Min. 9-1/4 inches (235 mm) Deep I-Joists. Max. 24 inches (610 mm) on center spacing. Min. flange thickness of 1-1/2 inches (38 mm) and each flange area of at least 3.45 inches² (2,226 mm²). Min. web thickness of 3/8 inch (9.5 mm).
- 5) Furring Channels: Min. 0.019-inch (0.5-mm) Hat Shaped Galvanized Steel Channels attached perpendicular to the bottom flange of the I-joint with Simpson Type CSC support clips at each intersection with the I-joists. Clips nailed to the side of bottom flange with one 1-1/2-inch (38-mm) long No. 11 gage nail. Channels are spaced a max. of 24 inches (610 mm) on center, are doubled at each wallboard end joint, and extend to the next joist beyond each joint. At channel splices, adjacent pieces overlapped a minimum of 6 inches (152 mm) and tied with a double strand of No. 18 gage galvanized steel wire at each end of the overlap. A row of furring channel located on each side of wallboard end joints and spaced 2-1/4 inches (57 mm) from the end joint (4-1/2 inches or 114 mm on center).
- 6) Ceiling: One layer of 1/2-inch (13-mm) Type C Gypsum Wallboard. Installed with long dimension perpendicular to furring channels and fastened with min. 1-inch (25-mm) Type S drywall screws spaced at 12 inches (305 mm) on center on intermediate joists, 6 inches (152 mm) on center at end joints, and 3/4 inch (19 mm) from wallboard edges and ends. The end joints of the wallboard must be staggered and the furring channels must extend a min. of 6 inches (152 mm) beyond each end of the joint.
 - a) Finish: The face layer joints must be covered with tape and coated with joint compound. Screw heads must also be covered with joint compound.

B. SOUND RATING^(a)

Components	STC	IIC
Base Assembly with Carpet and Padding	46	68
Base Assembly with cushioned vinyl, Gypsum Concrete	51	47
Base Assembly with Carpet and Padding, Gypsum Concrete	50	73

^(a) Sound ratings from the American Wood Council publication *Design for Code Acceptance (DCA) 3*. Available from www.awc.org/publications/DCA/DCA3/DCA3.pdf.

C. SIMILAR ASSEMBLIES

- 1) DCA 3 WIJ-1.4

* This assembly may also be used in a fire-rated roof/ceiling assembly, but only when constructed exactly as described.

REPRESENTING THE ENGINEERED WOOD INDUSTRY



Stark Truss Company Assembly SI1.5

One-Hour Fire Resistance Rated Floor/Ceiling Assembly*

This fire resistance design is listed in accordance with *American Wood Council's Design for Code Acceptance (DCA) 3*
SI-40, SI-60, and SI-80

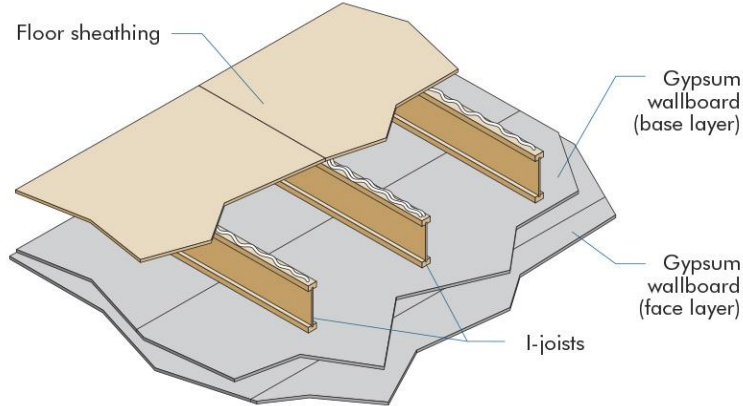

A. BASIC ASSEMBLIES

- 1) Floor Topping (Optional): Varies (reference sound ratings if applicable).
- 2) Floor Sheathing: Min. 23/32-inch (18-mm) T&G Wood Structural Panel. The sheets shall be installed with their long edge perpendicular to the joists with end joints centered over the top flange of joists. Floor sheathing must be installed per code requirements.
- 3) Structural Members: Min. 9-1/4 inches (235 mm) Deep I-Joists. Max. 24 inches (610 mm) on center spacing. Min. flange thickness of 1-1/2 inches (38 mm) and each flange area of at least 2.25 inches² (1,452 mm²). Min. web thickness of 3/8 inch (9.5 mm).
- 4) Ceiling: Two layers of 1/2-inch (13-mm) Type C Gypsum Wallboard.
 - a) Base Layer: Install with long dimension perpendicular to joist length. Attach to the bottom flange of the joists using 1-inch (25-mm) Type S drywall screws at 12 inches (305 mm) on center. The end joints of the wallboard must be centered on the bottom flange of the joist and must be staggered.
 - b) Face Layer: Install with long dimension perpendicular to joist length. Attach to the bottom flange of the joists through the base layer using 1-5/8-inch (41-mm) Type S drywall screws spaced at 12 inches (305 mm) on center on intermediate joists and 8 inches (203 mm) on center at end joints. The longitudinal joints of this layer must be offset 24 inches (610 mm) from those of the base layer. The end joints must be centered on the bottom flange of the joists and offset a min. of 48 inches (1219 mm) from those of the base layer. Additionally, face layer end joints are attached to the base layer with 1-1/2-inch (38-mm) Type G drywall screws at 8 inches (203 mm) on center with a 4-inch (102-mm) stagger, placed 6 inches (152 mm) either side of the joint.
 - c) Finish: The face layer joints must be covered with tape and coated with joint compound. Screw heads must also be covered with joint compound.

B. SOUND RATING^(a)

Components	STC	IIC
Base Assembly with Carpet and Padding, Gypsum Concrete	49	55

^(a) Sound ratings from the American Wood Council publication *Design for Code Acceptance (DCA) 3*. Available from www.awc.org/publications/DCA/DCA3/DCA3.pdf.

C. SIMILAR ASSEMBLIES

- 1) DCA 3 WIJ-1.5

* This assembly may also be used in a fire-rated roof/ceiling assembly, but only when constructed exactly as described.

REPRESENTING THE ENGINEERED WOOD INDUSTRY



Stark Truss Company Assembly SI1.6

One-Hour Fire Resistance Rated Floor/Ceiling Assembly*

This fire resistance design is listed in accordance with *American Wood Council's Design for Code Acceptance (DCA) 3*
Min. 9-1/2 inches (241 mm) Deep: SI-40, SI-60, and SI-80

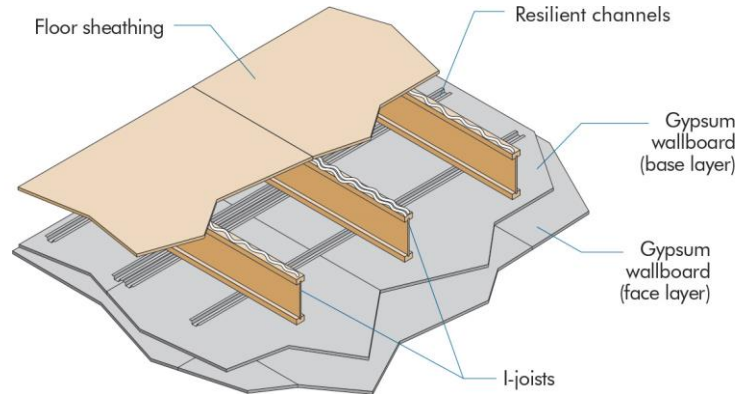

A. BASIC ASSEMBLIES

- 1) Floor Topping (Optional): Varies (reference sound ratings if applicable).
- 2) Floor Sheathing: Min. 23/32-inch (18-mm) T&G Wood Structural Panel. The sheets shall be installed with their long edge perpendicular to the joists with end joints centered over the top flange of joists. Floor sheathing must be installed per code requirements.
- 3) Structural Members: Min. 9-1/2 inches (241 mm) Deep I-Joists. Max. 24 inch (610 mm) on center spacing. Min. flange thickness of 1-5/16 inches (33 mm) and each flange area of at least 1.95 inches² (1,258 mm²). Min. web thickness of 3/8 inch (9.5 mm).
- 4) Resilient Channels†: Min. 0.019-inch (0.5-mm) Galvanized Resilient Channels. Attached perpendicular to the bottom flange of the I-joist with 1-1/4-inch (32-mm) Type S drywall screws. Channels are spaced a max. of 16 inches (406 mm) on center (24 inches or 610 mm when I-joists are spaced a max. of 16 inches or 406 mm on center), are doubled at each base layer wallboard end joint, and extend to the next joist beyond each joint.
- 5) Ceiling: Two layers of 1/2-inch (13-mm) Type X Gypsum Wallboard.
 - a) Base Layer: Install with long dimension perpendicular to resilient channels. Attach to the resilient channels using 1-1/4 inch (32-mm) Type S drywall screws at 12 inches (305 mm) on center. The end joints of the wallboard must be staggered.
 - b) Face Layer: Install with long dimension perpendicular to resilient channels. Attach to the resilient channels through the base layer using 1-5/8-inch (41-mm) Type S drywall screws spaced at 12 inches (305 mm) on center. The longitudinal joints of this layer must be offset 24 inches (610 mm) from those of the base layer. Additionally, face layer end joints are attached to the base layer with 1-1/2-inch (38-mm) Type G drywall screws at 8 inches (203 mm) on center placed 1-1/2 inches (38 mm) either side of the joint.
 - c) Finish: The face layer joints must be covered with tape and coated with joint compound. Screw heads must also be covered with joint compound.

B. SOUND RATING^(a)

Components	STC	IIC
Base Assembly with Carpet and Padding	54	68
Base Assembly with Carpet and Padding, Gypsum Concrete	58	55

^(a) Sound ratings from the American Wood Council publication *Design for Code Acceptance (DCA) 3*. Available from www.awc.org/publications/DCA/DCA3/DCA3.pdf.

C. SIMILAR ASSEMBLIES

- 1) DCA 3 WIJ-1.6

* This assembly may also be used in a fire-rated roof/ceiling assembly, but only when constructed exactly as described.

† Direct attachment of gypsum wallboard in lieu of attachment to resilient channels is typically deemed acceptable. When gypsum wall board is directly attached to the I-joists, the wallboard shall be installed with the long dimension perpendicular to the I-joists and sound rating for PK1.5 Assembly shall be used.

REPRESENTING THE ENGINEERED WOOD INDUSTRY



Stark Truss Company Assembly SI1.7

One-Hour Fire Resistance Rated Floor/Ceiling Assembly*

This fire resistance design is listed in accordance with *American Wood Council's Design for Code Acceptance (DCA) 3*
Min. 9-1/2 inches (241 mm) Deep: SI-40, SI-60, and SI-80

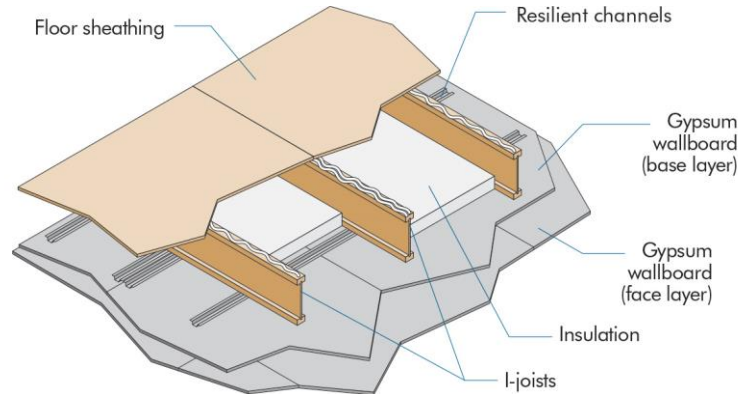

A. BASIC ASSEMBLIES

- 1) Floor Topping (Optional): Varies (reference sound ratings if applicable).
- 2) Floor Sheathing: Min. 23/32-inch (18-mm) T&G Wood Structural Panel. The sheets shall be installed with their long edge perpendicular to the joists with end joints centered over the top flange of joists. Floor sheathing must be installed per code requirements.
- 3) Insulation: Glass Fiber Insulation. Installed between I-joists and supported by resilient channels.
- 4) Structural Members: Min. 9-1/2 inches (241 mm) Deep I-Joists. Max. 24 inches (610 mm) on center spacing. Min. flange thickness of 1-1/2 inches (38 mm) and each flange area of at least 2.25 inches² (1,452 mm²). Min. web thickness of 3/8 inch (9.5 mm).
- 5) Resilient Channels: Min. 0.019-inch (0.5-mm) Galvanized Resilient Channels. Attached perpendicular to the bottom flange of the I-joist with 1-1/4 inch (32-mm) Type S drywall screws. Channels are spaced a max. of 16 inches (406 mm) on center (24 inches or 610 mm when I-joists are spaced a max. of 16 inches or 406 mm on center), are doubled at each base layer wallboard end joint, and extend to the next joist beyond each joint..
- 6) Ceiling: Two layers of 1/2-inch (13-mm) Type X Gypsum Wallboard.
 - a) Base Layer: Install with long dimension perpendicular to resilient channels. Attach to the resilient channels using 1-1/4 inch (32-mm) Type S drywall screws at 12 inches (305 mm) on center. The end joints of the wallboard must be staggered.
 - b) Face Layer: Install with long dimension perpendicular to resilient channels. Attach to the resilient channels through the base layer using 1-5/8-inch (41-mm) Type S drywall screws spaced at 12 inches (305 mm) on center. The longitudinal joints of this layer must be offset 24 inches (610 mm) from those of the base layer. Additionally, face layer end joints are attached to the base layer with 1-1/2-inch (38-mm) Type G drywall screws at 8 inches (203 mm) on center placed 1-1/2 inches (38 mm) either side of the joint.
 - c) Finish: The face layer joints must be covered with tape and coated with joint compound. Screw heads must also be covered with joint compound.

B. SOUND RATING^(a)

Components	STC	IIC
Base Assembly with cushioned vinyl	59	50
Base Assembly with Carpet and Padding	55	68
Base Assembly with cushioned vinyl, Gypsum Concrete	65	51
Base Assembly with Carpet and Padding, Gypsum Concrete	63	65

^(a) Sound ratings from the American Wood Council publication *Design for Code Acceptance (DCA) 3*. Available from www.awc.org/publications/DCA/DCA3/DCA3.pdf.

C. SIMILAR ASSEMBLIES

- 1) DCA 3 WIJ-1.7

* This assembly may also be used in a fire-rated roof/ceiling assembly, but only when constructed exactly as described.

REPRESENTING THE ENGINEERED WOOD INDUSTRY



Stark Truss Company Assembly SI1.8

One-Hour Fire Resistance Rated Floor/Ceiling Assembly*

This fire resistance design is listed in accordance with the International Building Code (IBC)
SI-40, SI-60, and SI-80

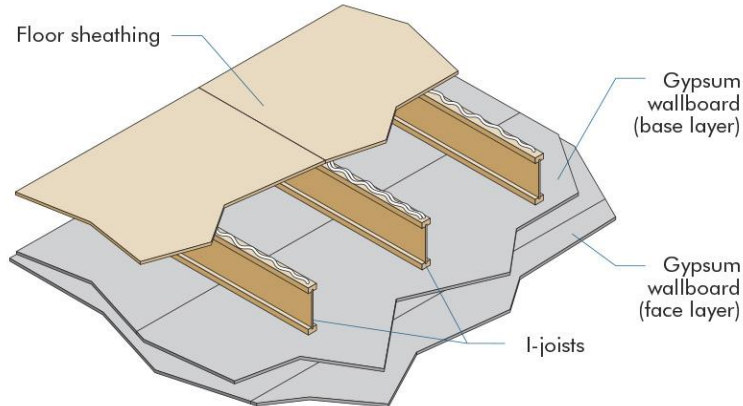

A. BASIC ASSEMBLIES

- 1) Floor Topping (Optional): Varies (reference sound ratings if applicable).
- 2) Floor Sheathing: Min. 23/32-inch (18-mm) T&G Wood Structural Panel. The sheets shall be installed with their long edge perpendicular to the joists with end joints centered over the top flange of joists. Floor sheathing must be installed per code requirements.
- 3) Structural Members: Min. 9-1/4 inches (235 mm) Deep I-Joists. Max. 24 inches (610 mm) on center spacing. Min. flange thickness of 1-1/2 inches (38 mm) and each flange area of at least 2.25 inches² (1,452 mm²). Min. web thickness of 3/8 inch (9.5 mm).
- 4) Ceiling: Two layers of 1/2-inch (13-mm) Type X Gypsum Wallboard.
 - a) Base Layer: Install with long dimension perpendicular to joist length. Attach to the bottom flange of the joists using 1-5/8-inch (41-mm) Type S drywall screws at 12 inches (305 mm) on center. The end joints of the wallboard must be centered on the bottom flange of the joist and must be staggered the equivalent of two joist spacings with those of adjacent sheets.
 - b) Face Layer: Install with long dimension perpendicular to joist length. Attach to the bottom flange of the joists through the base layer using 2-inch (51-mm) Type S drywall screws spaced at 12 inches (305 mm) on center on intermediate joists and 8 inches (203 mm) on center at end joints. Face layer end joint must not occur on the same joist as base layer end joints. The longitudinal joints of this layer must be offset 24 inches (610 mm) from those of the base layer. Additionally, face layer end joints are attached to the base layer with 1-1/2-inch (38-mm) Type G drywall screws at 8 inches (203 mm) on center placed 6 inches (152 mm) either side of the joint.
 - c) Finish: The face layer joints must be covered with tape and coated with joint compound. Screw heads must also be covered with joint compound.

B. SOUND RATING

Information not available.

C. SIMILAR ASSEMBLIES

- 1) 2009 IBC Table 720.1(3) Item 26-1.1 and 2012/2015/2018 IBC Table 721.1(3) Item 26-1.1

* This assembly may also be used in a fire-rated roof/ceiling assembly, but only when constructed exactly as described.

REPRESENTING THE ENGINEERED WOOD INDUSTRY



Stark Truss Company Assembly SI2.1
Two-Hour Fire Resistance Rated Floor/Ceiling Assembly*

This fire resistance design is listed in accordance with the International Building Code (IBC) and
American Wood Council's Design for Code Acceptance (DCA) 3
SI-40, SI-60, and SI-80

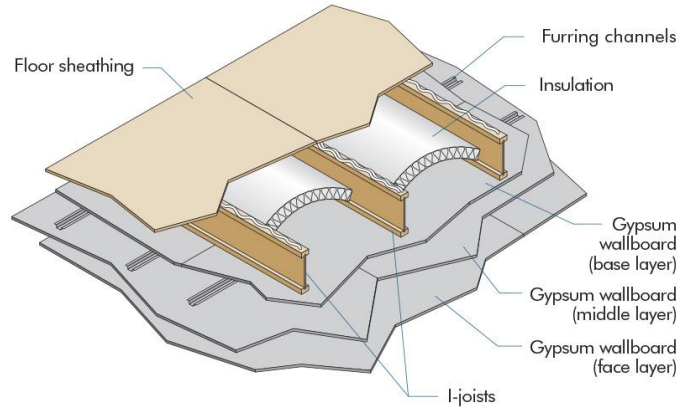

A. BASIC ASSEMBLIES

- 1) Floor Topping (Optional): Varies (reference sound ratings if applicable).
- 2) Floor Sheathing: Min. 23/32-inch (18-mm) T&G Wood Structural Panel. The sheets shall be installed with their long edge perpendicular to the joists with end joints centered over the top flange of joists. Floor sheathing must be installed per code requirements.
- 3) Insulation: 3-1/2-inch (89-mm) Unfaced Glass Fiber Insulation. Friction fitted between I-joists and supported by stay wires spaced 12 inches (305 mm) on center along the top of the I-joist bottom flange.
- 4) Structural Members: Min. 9-1/4 inches (235 mm) Deep I-Joists. Max. 24 inches (610 mm) on center spacing. Min. flange thickness of 1-1/2 inches (38 mm) and each flange area of at least 2.25 inches² (1,452 mm²). Min. web thickness of 3/8 inch (9.5 mm).
- 5) Furring Channels: Min. 0.0179-inch (0.45-mm) Hat Shaped Galvanized Steel Channels attached perpendicular to the bottom flange of the I-joist with 1-5/8-inch (41-mm) Type S drywall screws penetrating through the wallboard base layer into each I-joist flange. Channels are spaced a max. of 16 inches (406 mm) on center, are doubled at each base layer wallboard end joint, and extend to the next joist beyond each joint.
- 6) Ceiling: Three layers of 5/8-inch (16-mm) Type C Gypsum Wallboard.
 - a) Base Layer: Install with long dimension perpendicular to joist length. Attach to the bottom flange of the joists using 1-5/8-inch (41-mm) Type S drywall screws at 12 inches (305 mm) on center. The end joints of the wallboard must be centered on the bottom flange of the I-joist and must be staggered.
 - b) Middle Layer: Attached to furring channels using 1-inch (25-mm) Type S drywall screws at 12 inches (305 mm) on center with the long dimension perpendicular to furring channels. End joints must be staggered from end joints of adjacent sheets and end joints on the face layer.
 - c) Face Layer: Attached to furring channels through the middle layer using 1-5/8-inch (41-mm) Type S drywall screws spaced at 8 inches (203 mm) on center with long dimension perpendicular to furring channel. End joints must be staggered from end joints of adjacent sheets and staggered from end joints on the middle layer. Edge joints (long dimension) must be offset 24 inches (610 mm) from those of the middle layer.
 - d) Finish: The face layer joints must be covered with tape and coated with joint compound. Screw heads must also be covered with joint compound.

B. SOUND RATING^(a)

Components	STC	IIC
Base Assembly with Carpet and Padding	49	54
Base Assembly with cushioned vinyl, Gypsum Concrete	52	46
Base Assembly with Carpet and Padding, Gypsum Concrete	52	60

^(a) Sound ratings from the American Wood Council publication *Design for Code Acceptance (DCA) 3*. Available from www.awc.org/publications/DCA/DCA3/DCA3.pdf.

C. SIMILAR ASSEMBLIES

- 1) 2009 IBC Table 720.1(3) Item 28-1.1, 2012/2015/2018 IBC Table 721.1(3) Item 28-1.1, and DCA 3 WIJ-2.1

* This assembly may also be used in a fire-rated roof/ceiling assembly, but only when constructed exactly as described.

REPRESENTING THE ENGINEERED WOOD INDUSTRY

APA – The Engineered Wood Association is an approved national standards developer accredited by American National Standards Institute (ANSI). APA publishes ANSI standards and Voluntary Product Standards for wood structural panels and engineered wood products. APA is an accredited certification body under ISO/IEC 17065 by Standards Council of Canada (SCC), an accredited inspection agency under ISO/IEC 17020 by International Code Council (ICC) International Accreditation Service (IAS), and an accredited testing organization under ISO/IEC 17025 by IAS. APA is also an approved Product Certification Agency, Testing Laboratory, Quality Assurance Entity, and Validation Entity by the State of Florida, and an approved testing laboratory by City of Los Angeles.

**APA – THE ENGINEERED WOOD ASSOCIATION
HEADQUARTERS**

7011 So. 19th St. ▪ Tacoma, Washington 98466
Phone: (253) 565-6600 ▪ Fax: (253) 565-7265 ▪ Internet Address: www.apawood.org

PRODUCT SUPPORT HELP DESK
(253) 620-7400 ▪ *E-mail Address:* help@apawood.org

DISCLAIMER

APA Product Report® is a trademark of *APA – The Engineered Wood Association*, Tacoma, Washington. The information contained herein is based on the product evaluation in accordance with the references noted in this report. Neither APA, nor its members make any warranty, expressed or implied, or assume any legal liability or responsibility for the use, application of, and/or reference to opinions, findings, conclusions, or recommendations included in this report. Consult your local jurisdiction or design professional to assure compliance with code, construction, and performance requirements. Because APA has no control over quality of workmanship or the conditions under which engineered wood products are used, it cannot accept responsibility for product performance or designs as actually constructed.